

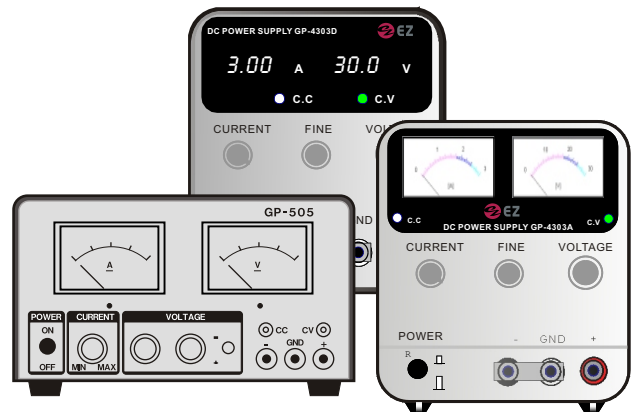

DC Power Supply

GP-4303D/GP-4303A
GP-4185D/GP-4185A
Operation manual



 **EZ Digital Co.,Ltd.**

GP - 4303D/GP - 4303A GP - 4185D/GP - 4185A Operation Manual

SAFETY SUMMARY

SAFETY PRECAUTIONS

Please take a moment to review these safety precautions.
They are provided for your protection and prevent damage to the power supply.

This safety information applied to all operator and service personnel.

If the equipment is used in a manner not specified by the manufacturer, the protection provided by the equipment may be impaired.

CAUTION AND WARNING STATEMENTS

CAUTION : Is used to indicate correct operating or maintenance procedures in order to prevent damage to or destruction of the equipment or other property.

WARNING : Calls attention to a potential danger that requires correct procedures or practices in order to prevent personal injury.

SYMBOLS



Caution, risk of electric shocks.
Easily-touched higher temperature parts.



Caution(refer to accompanying documents)



PROTECTIVE CONDUCTOR TERMINAL

INSTRUCTIONS

Thank you for purchasing EZ DIGITAL products.
The instruments produced by EZ DIGITAL are high products technology products made under strict quality control.

We guarantee their exceptional precision and utmost reliability.

For proper use of this product, please read this manual carefully.

EZ Digital Co., Ltd.

1. To maintain the precision and the reliability of the product , use it in the standard setting.

Operating temperature : 5 ~ 40
Operating humidity : 80% ~ 50%
Storage temperature : 0 ~ 70
Storage Humidity : less than 85%

2. For quality improvement , the exterior design and specifications of the product can be changed without notice.
3. Should any further information be required , please contact the EZ DIGITAL company or sales outlet.

WARRANTY

Warranty service covers one year the date of original purchase.

In case of technical failure a year, repair service will be provided by EZ DIGITAL company.

We charge for repairs after the one year warranty period expires.

When the failure is a result of user's neglect , natural disaster or accident , we charge for repairs regardless of the warranty period.

For more professional repair service , be sure to contact us or sales outlet.

CONTENTS

1. INTRODUCTION

2. FEATURES

3. PRECAUTIONS

3-1. Line voltage selection

3-2. Installation & handling precautions

3-3. Cleaning

4. SPECIFICATION

5. FRONT PANEL DESCRIPTION

6. OPERATIONS

6-1. Independent Operation

6-2. Serial Operation

6-3. Parallel Operation

7. NOTES ON ENVIRONMENTAL CONDITION

8. CURRENT LIMITING CIRCUIT

9. TO REPLACE THE FUSE

1. INTRODUCTION

GP-4303A/D, 4185A/D series are regulated DC POWER SUPPLY units with voltmeter and amperemeter : GP-4303A/D can supply the DC power of 0 to 30V/3A
GP-4185A/D can supply 0 to 18V/5A.
(A means Analog meter, D means Digital meter)

They are provided with continuously variable coarse adjustment and the output voltages and with continuously variable current adjustment in a range of 10 to 100%.

Current limiting and overload protection functions are built in to protect the over current.

The supply features analog voltmeter and amperemeter, enabling the user to monitor the supply's operation at a glance.

LEDs for Constant current (C.C) and Constant Voltage (C.V) enables monitoring of operation status.

Main input voltage AC115 or 230V selectable and 50/60Hz are supported.

2. FEATURE

Built in output current limit circuit (Overload Protection)

Availability of series and / or parallel operation

Constant Current and Constant Voltage

Low Ripple

Remote Control Operation (Analog Control Option)

Built in Analog Voltage meter and Amperemeter

3. PRECAUTIONS

3-1. Line voltage selection

This instrument must be operated with the correct line voltage selector switch setting and the correct line fuse for the line voltage selected to prevent damage.

The instrument operates from either a 90V to 132V or 198V to 250V line source. Before line voltage is applied to the instrument, make sure the line voltage selector switch is set correctly.

In the case of the line voltage selector switch selected, must be operated to the correct line fuse.

To change the line voltage selection

1. Make sure the instrument is disconnected from the power source.
2. Pull out the line voltage selector switch on the bottom panel.
Select the arrow mark position of the switch from Table 3-1.

Select the arrow mark to the desired position and plug it in.
3. Pull out the line fuse holder containing the fuse for overload protection.
Replace the fuse in the holder with the correct fuse from table3-1 & plug it in.

Table 3-1. Line voltage Selection & Fuse Ratings

Line Voltage	Select Switch Mark	Fuse Ratings (250V)
		GP-4303D/A, GP-4185D/A
AC 90 ~ 110	115V	T3.15A
AC 108 ~ 132		
AC 198 ~ 242	230V	T1.6A
AC 207 ~ 250		



For continued protection against fire, replace the line fuse only with a fuse of the specified type and rating.

3-2. INSTALLATION & HANDLING PRECAUTIONS

When placing the power supply in service at your workplace, observe the following precautions for best instrument performance and longest service life.

1. Avoid placing this instrument in an extremely hot and cold place.
Specifically, don't leave this instrument in a close car, exposed to sunlight in midsummer, or next to a space heater.

2. Don't use this instrument immediately after bring it in from the cold.
Allow time for it to warm to room temperature. Similarly don't move it from a warm place to a very cold place, as condensation might impair its operation.
3. Do not expose the instrument to wet or dusty environments.
4. Do not place liquid-filled containers on top of this instrument.
A spill could seriously damage the instrument.
5. Do not use this instrument where it is subject to severe vibration, or strong blows.
6. Do not place heavy objects on the case, or otherwise block the ventilation holes.
7. Do not use this power supply in strong magnetic fields, such as near motors.
8. Do not insert wires, tools, etc. through the ventilation holes.
9. Do not leave a hot soldering iron near the instrument.
10. Do not place this instrument face down on the ground, or damage to the knobs may result.
11. Do not connect other power source to +, -, of the output terminal.
12. Ground terminal of power cord must connect to the ground.
13. According to output polarity, it solved problem ESD and Floating voltage using the connect ground port to terminal of output.
14. To connect the ground, be careful at ground polarity of load.
15. Input voltage of instrument must be equal to AC power voltage.
16. It use to thick and short wire of output terminal in possible.

3-3. CLEARING

1. To clean stained casing, lightly rub the stained area with a soft cloth dipped in a neutral detergent.
2. If the surface of the panel is dirty, use the same method to clean.
If the panel is heavily stained, rub the affected area lightly with a soft cloth soaked in light neutral detergent or alcohol.
3. Never use highly volatile material such as benzene or paint thinner.

4. SPECIFICATIONS

Model	GP-4303D	GP-4303A	GP-4185D	GP-4185A
Output polarity	Positive & Negative			
Output current	0 ~3A		0 ~5A	
Ripple Voltage	Less than 2mVp-p			
Line Regulation	Less than 0.01% +2mV for power source voltage change of $\pm 10\%$			
Load Regulation	Less than 0.01% +3mV for load variation of 0 to 100%			
Voltmeter Accuracy	$\pm (1\% \pm 1\text{digit})$	2.5% F S	$\pm (1\% \pm 1\text{digit})$	2.5% F S
Ampermete Accuracy				
Insulation between	More than 10M Ω at DC 500V chassis and output terminal More than 50M Ω at DC 500V chassis and AC plug.			
Compensation/ Protection circuit	Overload protection circuit of constant current self restoring type			
Ambient temperature	5 ~ 40			
Operating Humidity	50% ~ 80%			
Dimension	131(W) x 150(H) x 273(D)			
Weight	Approx.4.5Kg			
Accessories	Short circuit Bar , Manual , Fuse			
Power source	AC 115/230V , 50/60Hz			
Power Consumption	130VA		130VA	

5. DESCRIPTION OF PANEL FUNCTION

5-1. Front Panel Description

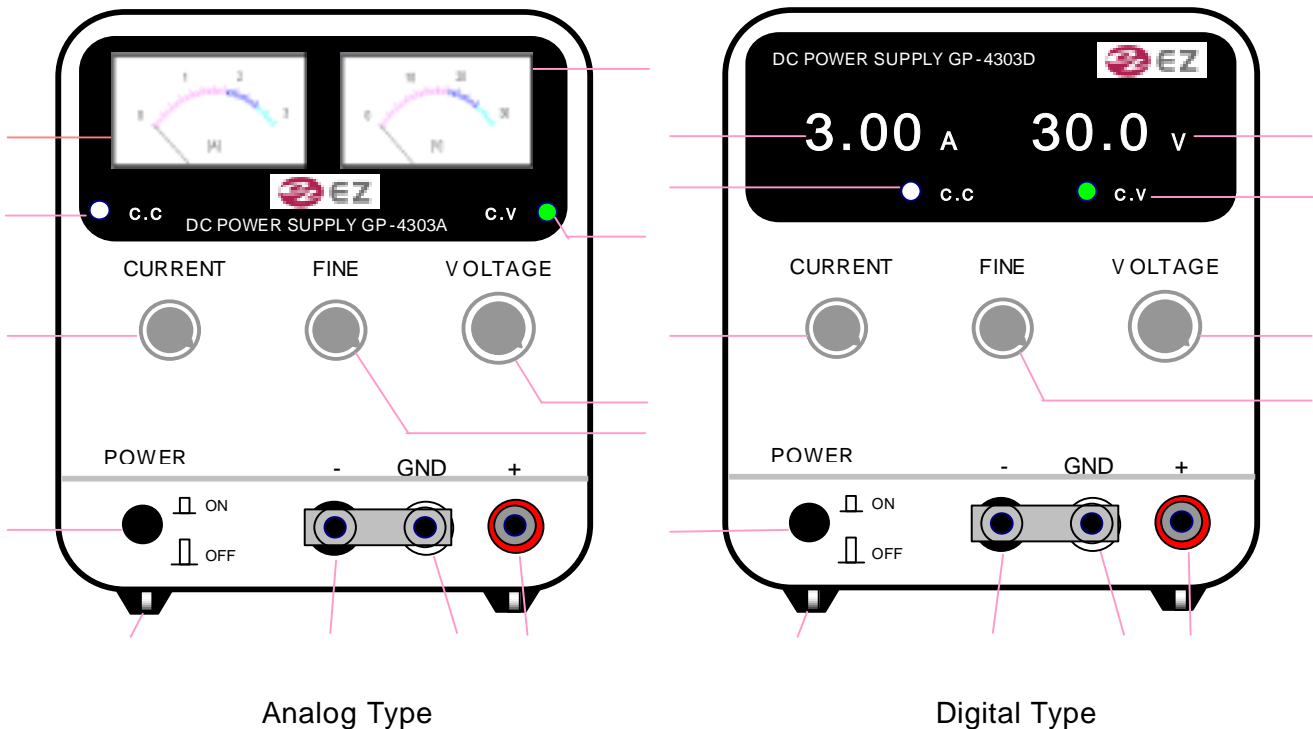

Analog Type

Digital Type

1. POWER SWITCH : This switch turns on and off the power.
2. CURRENT METER : Indicates the load current
3. VOLTAGE METER : Set an output voltage while reading the voltage indication.
4. C.C LED : Display LED for overcurrent.
5. C.V LED : Display LED for static state current & voltage operating.
6. CURRENT VR : The current limiting knob for setting and adjusting the output current in a range of max. 10 ~ 100%
7. FINE VR : The fine adjustment knob of the output voltage.
8. COARSE VR : The coarse adjustment knob of the output voltage.
9. OUTPUT TERMINAL (-) : The negative side of output terminal.
10. OUTPUT TERMINAL (GND) : When the positive polarity or negative polarity is to be connected to the ground, either an appropriate output terminal should be connected to the GND by a short circuit bar supplied as accessory.
When no bar connection is made, the terminal is used as the ground terminal
11. OUTPUT TERMINAL (+) : The positive side of output terminal.

6. OPERATIONS

6-1 INDEPENDENT OPERATION

- (1) The (+) terminal or the (-) terminal is to be connected always to the GND.
Terminal(GND) with short circuit bar as an accessory should be connected as shown in Fig6-1.
When positive output polarity is required.

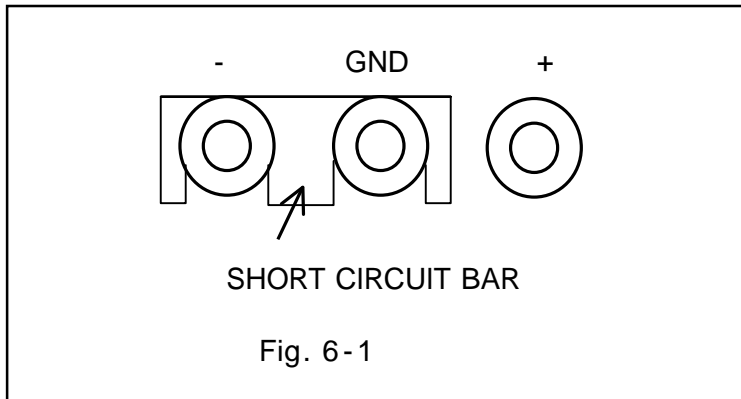

- (2) Connect the AC Power cord to the power source of the specified voltage, and turn on the power switch.
- (3) To set the load voltage, slowly turn the voltage adjusting knob (5) coarse clockwise with no load, while watching the amperemeter.
The knob (5) is for coarse adjustment, and the knob(4) is for fine adjustment.
- (4) Load current setting is used for limiting the current applied to a device to be tested at a specified power or to protect the device from the over current.
To set the current, connect the (+) and (-) terminals by a thick lead wire.
Slowly turn the current adjustment knob (3), and set the current while watching the amperemeter indication.
At this time, set the voltage adjustment knob (5) full counter clockwise and set the white mark of the FINE adjustment knob (4) at middle.

The minimum current that can be set is as follows.

GP-4303D/A : Approx. 200mA ~ 3A GP-4185D/A : Approx. 350mA ~ 5A

After setting a limiting current, remove the short circuit wire.
Then set the voltage to a required voltage level.

- (5) After completing the above procedure, watch the polarity of a device to be applied and use the instrument.
If the voltmeter indication becomes less than the set level for a defect of a device to be tested or for any other reason, the overcurrent protection circuit is activated, resulting in switching into the constant current operation from the constant voltage operation.
When the instrument is to be used in the constant voltage operating condition, set the current adjustment knob full clockwise.
In this case the short circuit current is 3A +10% for the GP-503, 5A +10% for the GP-305/505, and 10A + 5% for the GP-3010.

6-2 SERIES OPERATION

(1) By connecting a couple of the units in series a higher voltage than a single unit is available. In such a case, no terminal should be applied with a voltage more than the rating voltage against the ground potential between a terminal and panel chassis. The rating voltage against the ground is $\pm 100V$.

With a series operation of couple of the units, a double of the rating voltage of a single unit and current of a single units is available.

When two unit, either GP-4303A/D are used the maximum voltage available +60V or -60V.

When two unit, either GP-4185A/D are used the maximum voltage available +36V or -36V

NOTE : 1. The overcurrent protection is effective at the smaller value of the two.
2. Series operation between other types is not available.

(2) Notes on series operation

When the series connected two units of regulated DC power supplies are overloaded, the unit in which the overcurrent protection circuit activated first is applied with the reverse voltage from the output of the unit, and so the series control element of the former will be damaged.

To protect this problem, connect two diodes between the output terminals of the units as shown in Fig.6-2

Diodes to be used should be with a high voltage than the maximum rating voltage of a single unit, and the voltage rating of diodes should be 2 to 3 times of the maximum voltage of the series connection.

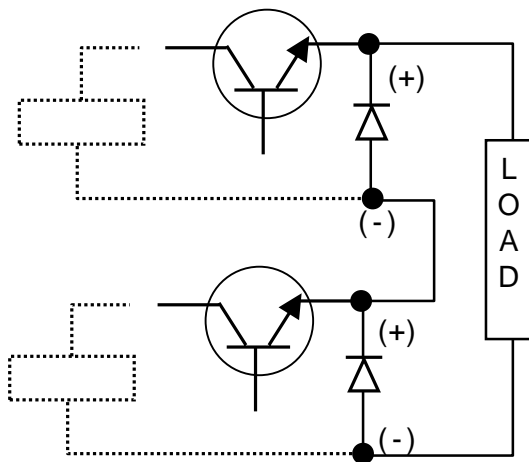

Fig. 6-2

(3) Connection

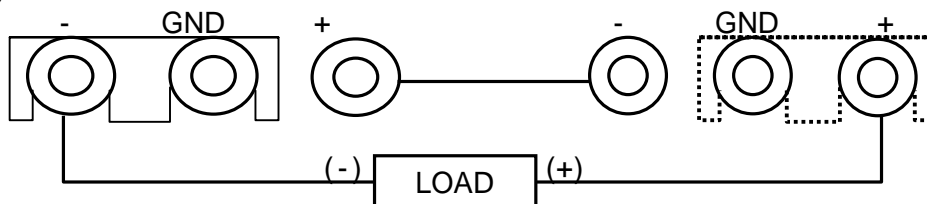

Fig. 6-3

(a) For the negative grounding : As shown by a solid line fig.6-3

(b) For the positive grounding : As shown by a dotted line fig.6-3

Do not connect the GND terminal to different polarities other than fig.6-3

6-3 PARALLEL OPERATION

(1) When a current capacity larger than a single unit is required, a couple of the units may be used in a parallel connection.

In a parallel operation, a unit becomes the main unit and other becomes the sub-unit. Setting of the voltage and current should be made of the main unit.

(2) Connection

Make the connection while the power off.

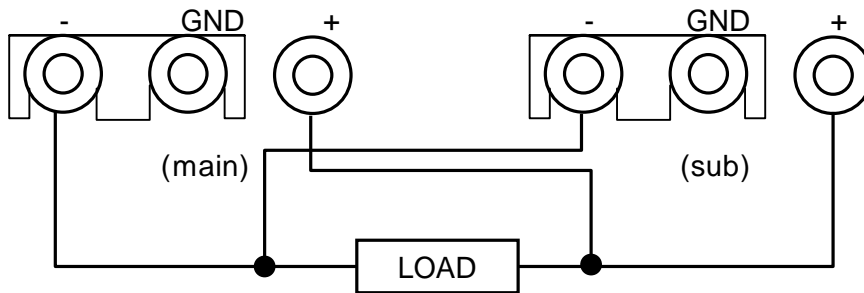

Fig.6-4

For parallel operation, make the connection in the sequence of the (+) terminal of the main unit, (+) terminal of the sub-unit, (-) terminal of the main unit, and (-) terminal of the sub-unit. Then connect the wires between the Parallel terminal (main unit) and the Parallel terminal (sub unit). Use thick wires for all the connections.

(a) Turn the voltage knob (5), (4) and the current knob (3) of the sub unit full clockwise.

(b) The voltage and current are variable by the main unit.

The output current limit can be selected within a range of about 10 to 100% of the double of the maximum rating current.

In this case, as the load current increases, the ampere meters of both main and sub units swing, and the load current is indicated as the sum of both amperemeters.

NOTES : Other type of regulated DC Power supply can be connected for parallel operation. The maximum number of units for parallel operation is limited to 2 units.

7. NOTES ON ENVIRONMENTAL CONDITION

7-1. Avoid using the unit in such a place where the ambient temperature exceeds 40 °C or under the direct sun shines.

Limit the maximum output current when the unit is used in such a place where ventilation is interrupted or a radiation exists other equipments.

7-2. Use the instrument within 10% tolerance of the specified from the power source.

8. CURRENT LIMITING CIRCUIT

When the output terminals are short circuited by mistake, the current limiting circuit is activated to limit the flow of the current in excess of the rating output current, so that the control elements and the amperemeters connected in series operation can be protected from the sudden damage.

The output limit current can be set in a range from 10 to 100% of the rating current, and when the output current reaches the set value, the instrument operates in the constant current condition.

As the output current comes down below the set value, the constant voltage condition is automatically resumed.

9. TO REPLACE THE FUSE

Pull out F1 below with screw driver and get rid of F1, take out spare Fuse in the holder and put it in the position of F1.

